

**66/100 MHz PC SDRAM 64-Bit Non-ECC/Parity 144  
Pin UNBUFFERED SO-DIMM SPECIFICATION**

**Revision 1.0  
February 1999**

**Intel Corporation**

THIS DOCUMENT IS PROVIDED "AS IS" WITH NO WARRANTIES WHATSOEVER, INCLUDING ANY WARRANTY OF MERCHANTABILITY, FITNESS FOR ANY PARTICULAR PURPOSE, OR ANY WARRANTY OTHERWISE ARISING OUT OF ANY PROPOSAL, SPECIFICATION, OR SAMPLE.

No license, express or implied, by estoppel or otherwise, to any intellectual property rights is granted herein.

Intel disclaims all liability, including liability for infringement of any proprietary rights, relating to implementation of information in this specification. Intel does not warrant or represent that such implementation(s) will not infringe such rights.

\* Other brands and names are the property of their respective owners.

Copyright Intel Corporation, 1999

## Changes:

### **Revision 1.0 October, 1998**

Added 256Mbit support, and changed decoupling.

### **Revision 0.7 August 14, 1998**

Added clock trace length data, and PB marking information.

### **Revision 0.51 July 15, 1998**

Added figures 14 and 15

### **Revision 0.5 July 14, 1998**

Add support for 66MHz

### **Revision 0.3 June 12, 1998**

Removed support of X8 components

### **Revision 0.22 April 15, 1998**

First external copy.

## TABLE OF CONTENTS

<b>LIST OF TABLES</b>	<b>5</b>
<b>LIST OF FIGURES</b>	<b>6</b>
<b>1.0 INTRODUCTION</b>	<b>7</b>
<b>2.0 ENVIRONMENTAL REQUIREMENTS</b>	<b>9</b>
<b>3.0 MECHANICAL DESIGN</b>	<b>10</b>
<b>4.0 MODULE PINOUT</b>	<b>14</b>
<b>5.0 SO-DIMM PCB BLOCK DIAGRAMS</b>	<b>15</b>
<b>6.0 SO-DIMM PCB LAYOUT AND SIGNAL ROUTING</b>	<b>17</b>
<b>7.0 SO-DIMM PCB AND FINAL ASSEMBLY LABELING REQUIREMENTS</b>	<b>28</b>
<b>8.0 SDRAM COMPONENT SPECIFICATIONS</b>	<b>28</b>
<b>9.0 EEPROM COMPONENT SPECIFICATIONS</b>	<b>28</b>

## LIST OF TABLES

TABLE 1: RELATED DOCUMENTS	7
TABLE 2: SDRAM NON MIXED-MODE MODULE CONFIGURATIONS	8
TABLE 3: SDRAM MIXED-MODE MODULE CONFIGURATIONS	8
TABLE 4: SO-DIMM REFERENCE DESIGNS	8
TABLE 5: SO-DIMM ENVIRONMENTAL REQUIREMENTS	9
TABLE 6: SO-DIMM DIMENSIONS AND TOLERANCES	10
TABLE 7: SDRAM SO-DIMM PINOUT	14
TABLE 8: PCB CALCULATED PARAMETERS	17
TABLE 9: SIGNAL TOPOLOGY CATEGORIES	19
TABLE 10: TRACE LENGTH TABLE FOR CLOCK TOPOLOGIES	21
TABLE 11: TRACE LENGTH TABLE FOR CLOCKS TO ROWS WITH OPTIONAL STUFFING	22
TABLE 12: TRACE LENGTH TABLE FOR DATA TOPOLOGIES	23
TABLE 13: TRACE LENGTH TABLE FOR DATA MASK TOPOLOGIES (1/2 LOADS)	24
TABLE 14: TRACE LENGTH TABLE FOR CHIP SELECT TOPOLOGIES	25
TABLE 15: TRACE LENGTH TABLES FOR CLOCK ENABLE TOPOLOGIES	26
TABLE 16: TRACE LENGTH TABLE FOR DOUBLE CYCLE SIGNAL TOPOLOGIES	27

## LIST OF FIGURES

FIGURE 1: SO-DIMM WITH FOUR 54-PIN OR 50-PIN SDRAM PER SIDE	7
FIGURE 2: SO-DIMM WITH TWO 54-PIN OR 50-PIN SDRAM PER SIDE	7
FIGURE 3: SO-DIMM MECHANICAL DRAWING (1 OF 5)	11
FIGURE 4: SO-DIMM MECHANICAL DRAWING (2 OF 5)	12
FIGURE 5: SO-DIMM MECHANICAL DRAWING (3 OF 5)	12
FIGURE 6: SO-DIMM MECHANICAL DRAWING (4 OF 5)	13
FIGURE 7: SO-DIMM MECHANICAL DRAWING (5 OF 5)	13
FIGURE 8: 64-BIT NON-ECC SO-DIMM BLOCK DIAGRAM (1 ROW, X16 SDRAMs)	15
FIGURE 9: 64-BIT NON-ECC SO-DIMM BLOCK DIAGRAM (2 ROWS, X16 SDRAMs)	16
FIGURE 10: EXAMPLE 6-LAYER PCB STACKUP	17
FIGURE 11: SIGNAL ROUTING TOPOLOGIES FOR CLOCKS	21
FIGURE 12: SIGNAL ROUTING TOPOLOGIES FOR CLOCKS TO ROWS WITH OPTIONAL STUFFING	22
FIGURE 13: SIGNAL ROUTING TOPOLOGIES FOR DATA	23
FIGURE 14: SIGNAL ROUTING TOPOLOGIES FOR DATA MASK (1/2 LOADS)	24
FIGURE 15: SIGNAL ROUTING TOPOLOGIES FOR CHIP SELECT	25
FIGURE 16: SIGNAL ROUTING TOPOLOGIES FOR CLOCK ENABLE	26
FIGURE 17: SIGNAL ROUTING TOPOLOGIES FOR DOUBLE CYCLE SIGNALS	27

## 1.0 Introduction

This specification defines the electrical, mechanical, and trace routing requirements for 144-pin, 3.3 volt, 66/100 MHz, 64-bit wide (non-ECC/Parity), 2 clock, unbuffered Synchronous DRAM Small Outline Dual In-Line Memory Modules (SDRAM SO-DIMMs). These SDRAM SO-DIMMs are intended for use as main memory installed in personal notebook computer motherboards.

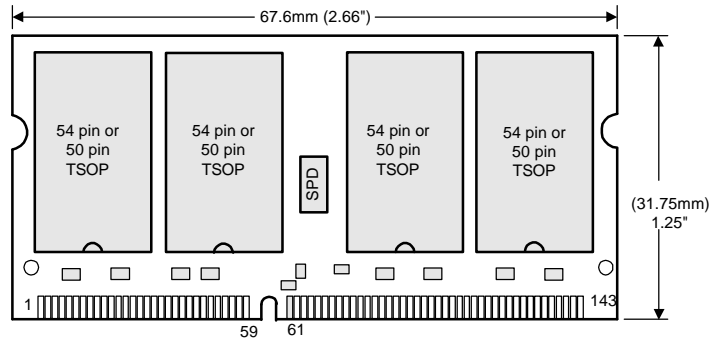

**Figure 1: SO-DIMM with four 54-pin or 50-pin SDRAM per side**

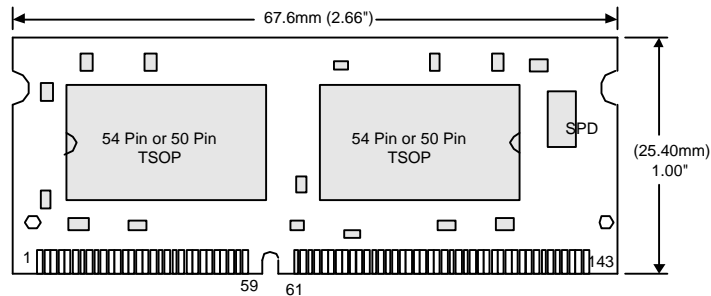

**Figure 2: SO-DIMM with two 54-pin or 50-pin SDRAM per side**

### Related Documents

The related documents contain information that is critical to this specification. The revisions listed are the latest releases at the time of this writing. However, it is important to use the most current revisions of each of these documents when generating or modifying SO-DIMM designs.

**Table 1: Related Documents**

TITLE	REV	DATE
Intel PC/100 SDRAM Specification	1.62	Sept. 1998
Intel SDRAM SPD Data Structure Specification	1.2A	April 1997

**SO-DIMM Configurations**

SDRAM SO-DIMM configurations are defined in the following tables:

**Table 2: SDRAM Non Mixed-Mode Module Configurations**

Config #	SO-DIMM Capacity	SO-DIMM Organization	SDRAM density	SDRAM Organization	# of SDRAMs	# Rows of SDRAM	# Banks in SDRAM	# Address bits row/bank/col
1	8 MB	1M X 64	16 Mbit	1MX16	4	1	2	11/1/8
2	16 MB	2M X 64	16 Mbit	1MX16	8	2	2	11/1/8
3	32 MB	4M X 64	64 Mbit	4MX16	4	1	4	12/2/8
4	64 MB	8M X 64	64 Mbit	4MX16	8	2	4	12/2/8
5	64 MB	8M X 64	128 Mbit	8MX16	4	1	4	12/2/9
6	128 MB	16M X 64	128 Mbit	8MX16	8	2	4	12/2/9
7	128 MB	16M X 64	256 Mbit	16MX16	4	1	4	13/2/9
8	256 MB	32M X 64	256 Mbit	16MX16	8	2	4	13/2/9

**Table 3: SDRAM Mixed-Mode Module Configurations**

Config #	SO-DIMM Capacity	SO-DIMM Organization	SDRAM density	SDRAM Organization	# of SDRAMs	# of Rows of SDRAM	Banks in SDRAM	# Address bits row/bank/col
M1	40 MB	1M x 64 + 4M x 64	16 Mb	1Mb x 16	4	2	2	11/1/8
			64 Mb	4Mb x 16	4			4
M2	72 MB	1M x 64 + 8M x 64	16 Mb	1Mb x 16	4	2	2	11/1/8
			128 Mb	8Mb x 16	4			4
M3	136 MB	1M x 64 + 16M x 64	16 Mb	1Mb x 16	4	2	2	11/1/8
			256 Mb	16Mb x 16	4			4
M4	96 MB	4M x 64 + 8M x 64	64 Mb	4Mb x 16	4	2	4	12/2/8
			128 Mb	8Mb x 16	4			4
M5	160 MB	4M x 64 + 16M x 64	64 Mb	4Mb x 16	4	2	4	12/2/8
			256 Mb	16Mb x 16	4			4
M6	192 MB	8M x 64 + 16M x 64	128 Mb	8Mb x 16	4	2	4	12/2/9
			256 Mb	16Mb x 16	4			4

The following SO-DIMMS will be designed at Intel and offered as reference designs.

**Table 4: SO-DIMM Reference Designs**

Config #	SO-DIMM Capacity	SDRAM density	SDRAM Organization	# Rows of SDRAM	# Banks in SDRAM	Size of SO-DIMM	Corresponding Figure
3 / 5 / 7	32 MB / 64 MB / 128 MB	64, 128, 256 Mbit	4MX16 / 8MX16 / 16MX16	1	4	1.00	Figure 2
4 / 6 / 8	64 MB / 128 MB / 256 MB	64, 128, 256 Mbit	4MX16 / 8MX16 / 16MX16	2	4	1.25	Figure 1

**Distinction between “banks” and “rows”**

This document only uses “banks” when referring to banks of memory internal to the SDRAM component (two or four). “Rows” is used to define the number of sets of SDRAMs on the SO-DIMM that collectively make up 64 bits of data.

## 2.0 Environmental Requirements

The SDRAM SO-DIMM shall be designed to operate within a notebook personal computer in a variety of environments. The temperature and humidity limits are as follows.

**Table 5: SO-DIMM Environmental Requirements**

Operating Temperature	0 °C to +65 °C ambient
Operating Humidity	10% to 90% relative humidity, noncondensing
Operating Pressure	10.106 PSI (up to 10,000 ft.)
Storage Temperature	-40 °C to + 70 °C
Storage Humidity	5% to 95% without condensation
Storage Pressure	1.682 PSI (up to 50,000 ft.) at 50 °C

### Safety - UL Rating

Printed circuit board to have a flammability rating of 94V-O Markings to include UL tractability requirements per UL Recognized Component Directory.

### 3.0 Mechanical Design

The following table and drawings give the specific dimensions and tolerances for a 144-pin SO-DIMM.

**Table 6: SO-DIMM Dimensions and Tolerances**

SYMBOL	DEFINITION	MIN	NOM	MAX	NOTES
A	Overall module height measured from Datum -B-.	25.25 mm	25.40 mm	25.55 mm	Two sizes available: "1 inch" and "1.25 inch".
		31.60 mm	31.75 mm	31.90 mm	
A1	The distance from Datum -B- to the centerline of the PWB alignment holes	6.00 mm BASIC			These holes are not used by the next level of assembly. The dimensions are supplied for information only. If the holes are used in manufacturing they should be tightly tolerated. The recommended positional tolerance is 0.10 mm.
A2	The distance from Datum -B- to the lower edge of the Component Area on the front side of the PWB.	3.2 mm			
A3	The distance from Datum -B- to the lower edge of the Component Area on the back side of the PWB.	4.0 mm			Dimensions applicable when components mounted on both sides. Application note: border of component area.
A4	The distance from Datum -B- to the centerline of the latch holes	20.00 mm BASIC			
D	The overall length of the PWB	67.45 mm	67.60 mm	67.75 mm	
D1	The distance between the centerline of the contact at the immediate left of the key zone and the inner edge of the left latch hole.	24.50 mm BASIC			
D2	The distance between the inner edge of the latch holes	63.60 mm BASIC			
D3	The distance between Datum -A- and the center of the contact at the immediate left of the key zone on the front side of the PWB.	2.50 mm BASIC			The position of the notch indicates that the operating voltage is 3.3 Volts. The centerlines of contacts on the front side of the PWB are not coincident with the centerlines of contacts on the backside of the PWB
D4	The distance between Datum -A- and the center of the contact at the immediate left of the key zone on the backside of the PWB.	2.10 mm BASIC			
D5	The distance between the centerline of D Datum -A-.	4.80 mm BASIC			
E	The overall thickness of the PWB with the components mounted. The overall thickness is measured from the highest component on the front side to the highest component on the backside			3.80 mm	Dimensions applicable when components mounted on both sides.
e1	The distance between the centerline of the contact to the immediate left of the key zone and the center of the left most contact.	23.20 mm BASIC			
e2	The distance between the centerline of the contact to the immediate right of the key zone and the center of the right most contact.	32.80 mm BASIC			



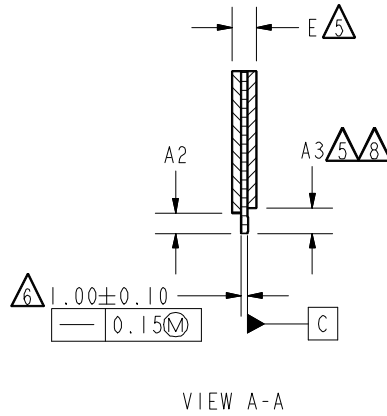

**Figure 4: SO-DIMM Mechanical Drawing (2 of 5)**

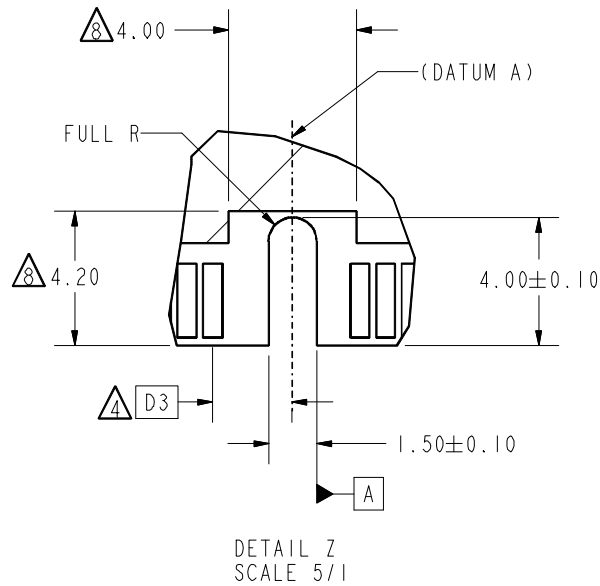

**Figure 5: SO-DIMM Mechanical Drawing (3 of 5)**

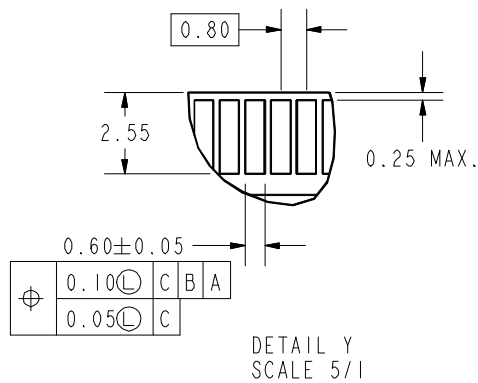

Figure 6: SO-DIMM Mechanical Drawing (4 of 5)

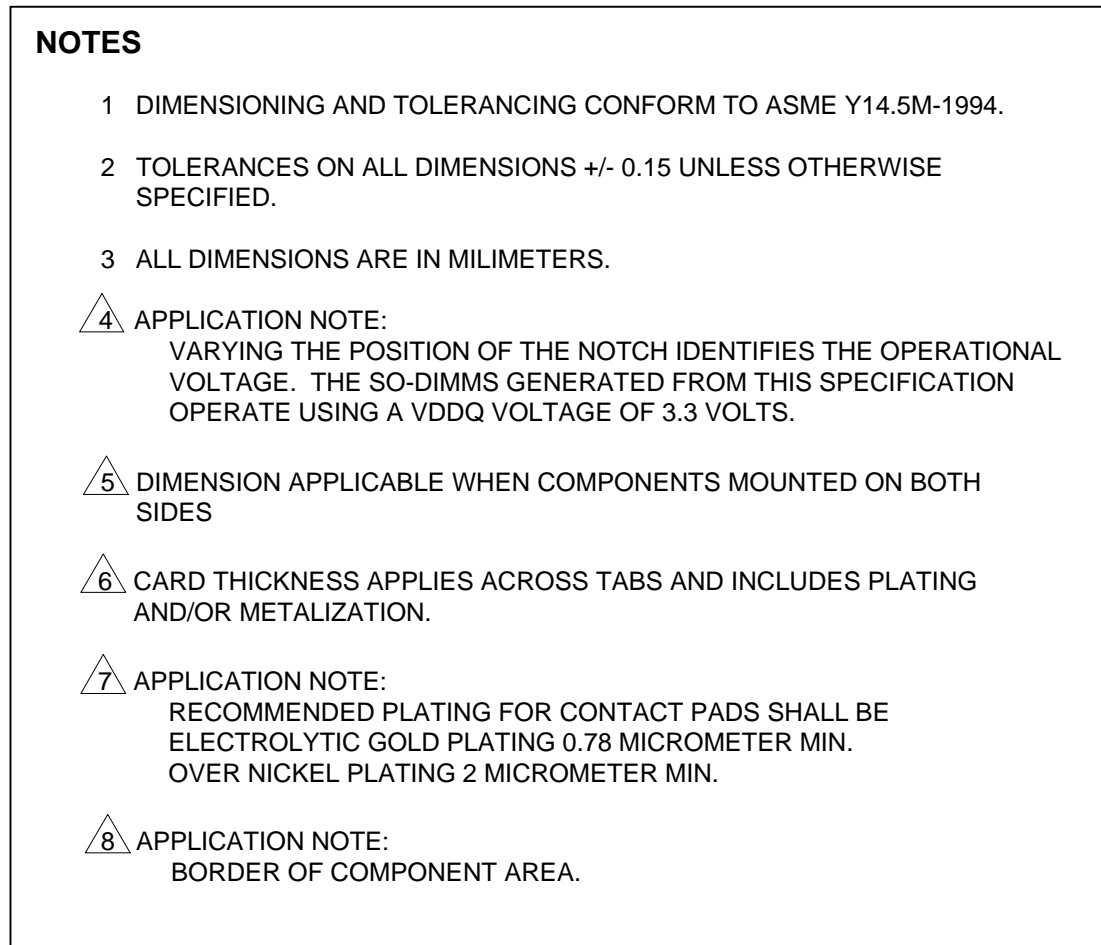

Figure 7: SO-DIMM Mechanical Drawing (5 of 5)

#### Explanation of SO-DIMM Keying

All SO-DIMMs generated from this spec should have a notch cut into the edge connection that conveys information on the voltage of the SO-DIMM. The notch should be positioned between SO-DIMM pins 59 and 61 and should be centered between the two pins. This signifies that the SO-DIMM operates using a Vddq voltage of 3.3 Volts. Please see the mechanical drawings above for exact dimensions and placement of the notch.



### 5.0 SDRAM SO-DIMM Block Diagrams

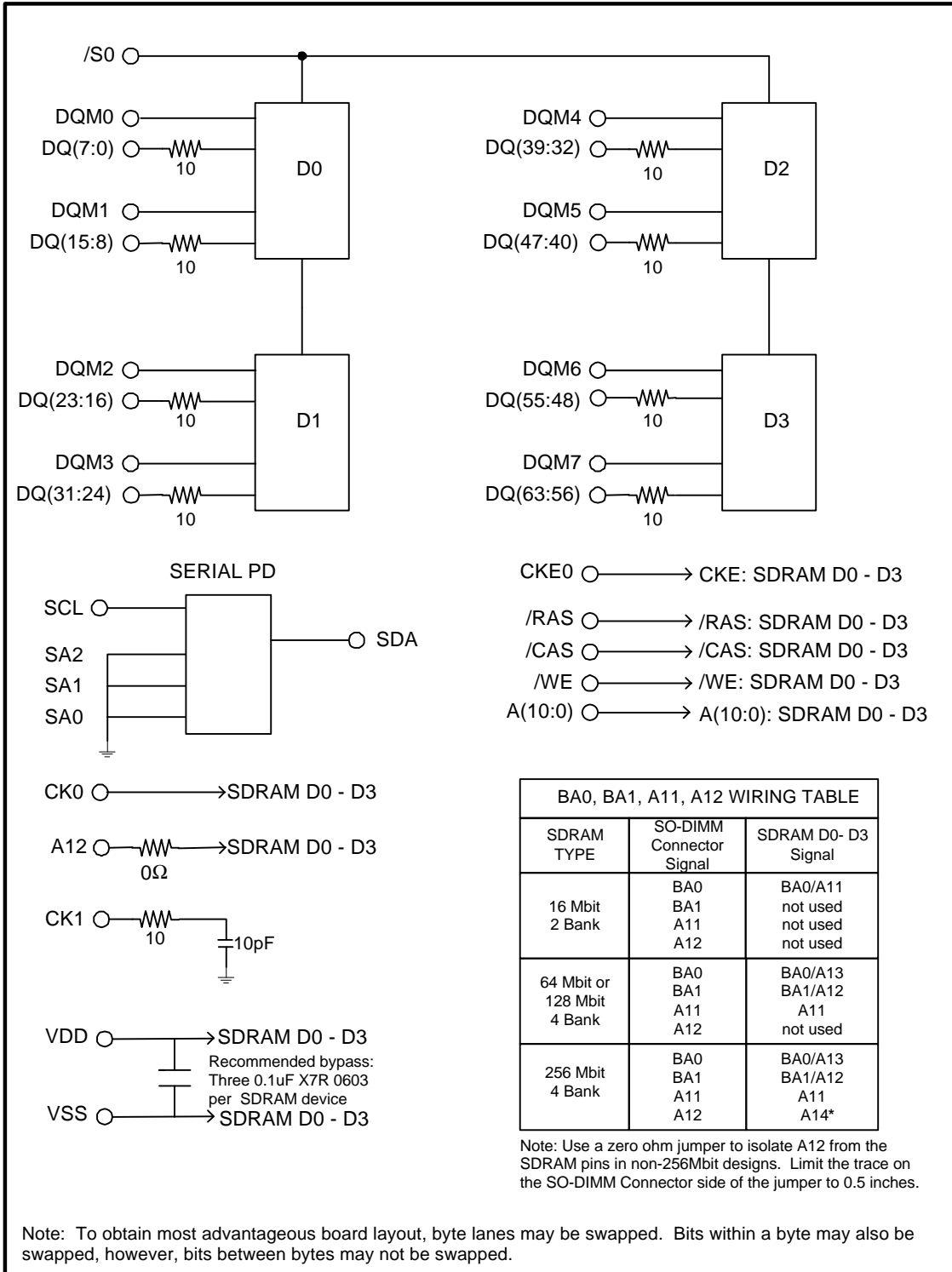

Figure 8: 64-bit non-ECC SO-DIMM Block Diagram (1 Row, x16 SDRAMs)

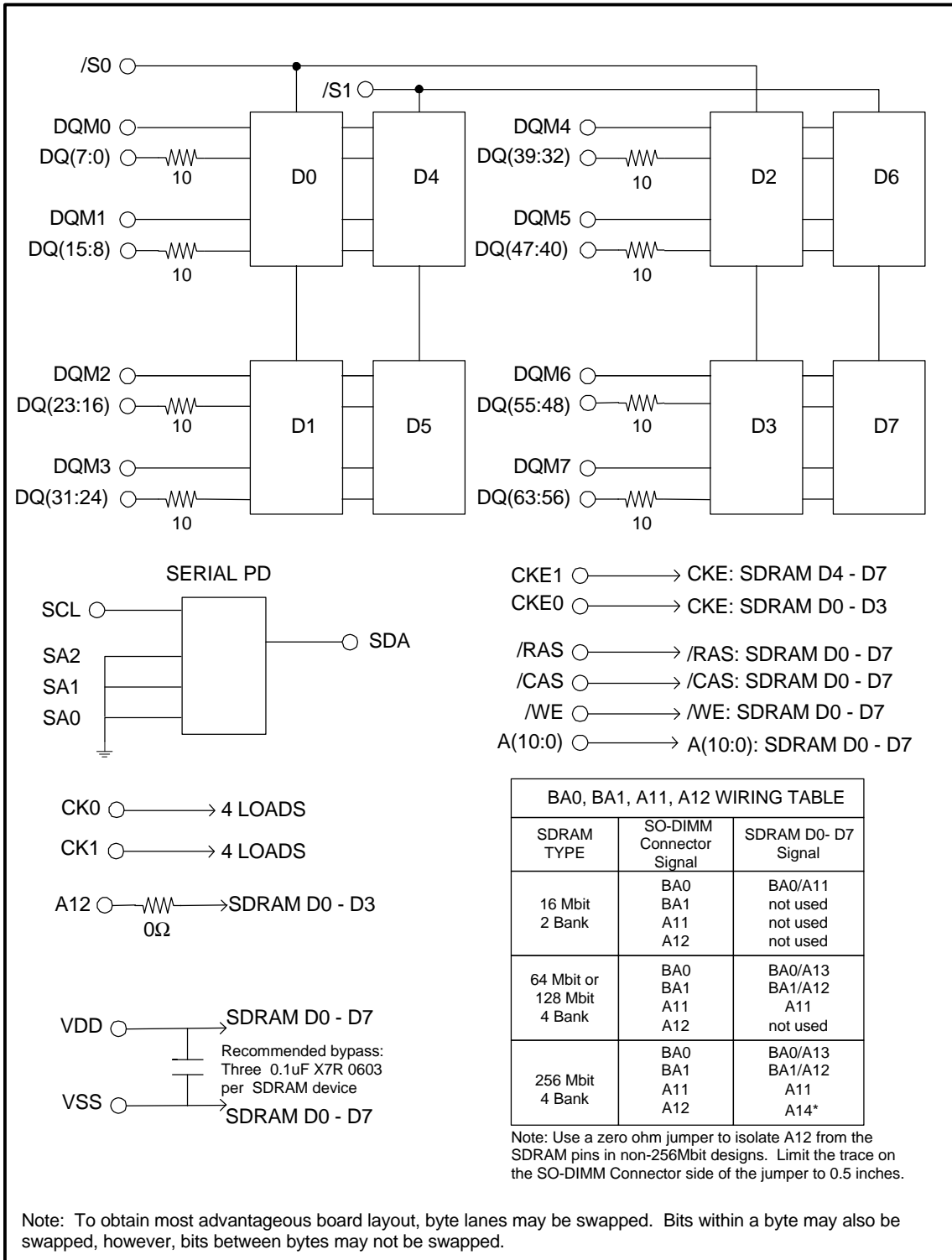

Figure 9: 64-bit non-ECC SO-DIMM Block Diagram (2 Rows, x16 SDRAMs)

## 6.0 SO-DIMM PCB Layout and Signal Routing

### Printed Circuit Board

The SO-DIMM printed circuit board shall be at least a six layer stack-up using glass epoxy material. The PCB must have both a full ground plane layer and a full power plane layer. The required signal trace impedance is  $55\Omega \pm 15\%$ . Components shall be of surface mount type, and may be mounted on one or both sides of the PCB.

**Table 8: PCB Calculated Parameters**

Parameter	Min	Max
Propagation delay: $S_0$ [ps/in] (outer layers)	141	153
Propagation delay: $S_0$ [ps/in] (inner layers)	167	180
Trace impedance: $Z_0$ [ $\Omega$ ] (all layers)	47	63

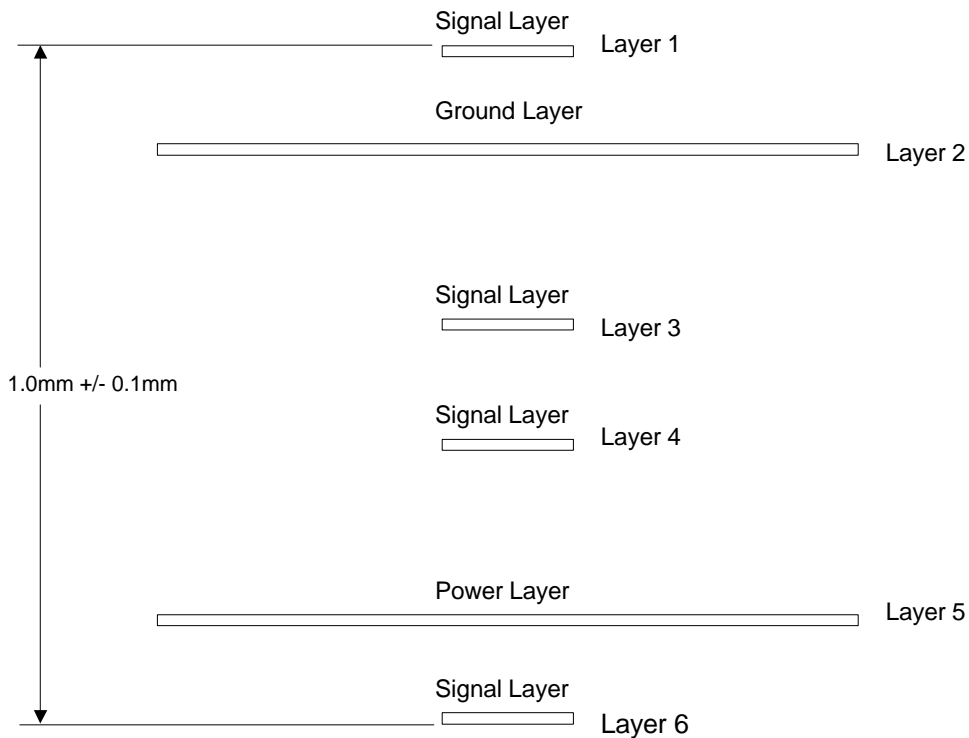

**Figure 10: Example 6-layer PCB Stackup**

## Edge Connection

The PCB edge connector contacts shall be gold plated per Figure 7, Note 7. Note: The PCB connector edge will not be chamfered.

## EMI Reduction

To minimize radiation from clock traces on the SO-DIMMs, the following are requirements:

- Clocks must be routed with as much of the trace on an inner signal layer as possible.
- Clocks on the inner layer will have a 5 mill ground trace surrounding them, with vias stitched to ground at 0.5" intervals, or as often as routing allows.
- Both internal signal layers and the power plane should have a ground ring routed around the perimeter of the board and stitched to ground at intervals <0.5". The ground rings should be on the order of 20 mils wide, but can be reduced to 10 mils in areas where 20 mils cannot be accommodated.

## Component Types and Placement

Components shall be of surface mount type, and may be mounted on one or both sides of the PCB. Components shall be positioned on the PCB to meet the min and max trace lengths required for SDRAM data signals. Bypass capacitors for SDRAM devices must be located as near as practical to the device power pins. It is also important to place each SDRAM in the optimum position to ensure meeting of trace length and topology requirements. Pin swapping of data pins within individual bytes should also be used for the same reason.

Exact spacing numbers are not provided, but are left up to the SO-DIMM manufacturer to determine based on manufacturing constraints and signal routing constraints imposed by this specification.

## Signal Groups

In this specification, the SDRAM timing-critical signals have been divided into groups whose members have identical loading and routing topologies. The following table summarizes the signal groups by listing the signals contained in each. The following sections will describe routing restrictions associated with each signal group.

**Table 9: Signal Topology Categories**

SIGNAL GROUP	SIGNALS IN GROUP
Clock	CLK [1:0]
Data	DQ [63:0]
Data Mask	DQMB [7:0]
Chip Select	S#[1:0]
Clock Enable	CKE[1:0]
Double cycle signals	A[12:0]
	BA[1:0]
	RAS#
	CAS#
	WE#

## Signal Topology and Length Restrictions

In order to meet signal quality and setup/hold time requirements for the memory interface, certain routing topologies and trace length requirements must be met. The signal topology requirements are shown pictorially in the following pages. Each topology diagram is accompanied by a trace length table that lists the minimum and maximum lengths allowed for each trace segment and, where applicable, the min and max lengths for the entire net. Each diagram also shows where vias are allowed or includes a note that specifies where vias are allowed if they are not shown in the diagram.

## Routing Rules

General Info: All signal traces except clocks are routed using 5/5 rules.  
(5 mil traces and 5 mil minimum spacing between adjacent traces).

Clocks are routed using 5 mil traces and 5 mil space to the 5 mil ground trace.

No test points are required.

### Topology Diagram Explanation

The routing topology diagrams in this section are intended to be used to determine individual signal topologies on a SO-DIMM for any supported configuration.

These diagrams are read as follows:

Only the cylinders labeled with length designators represent actual physical trace segments. All other lines should be considered zero in length.

All loads and traces outside of the dashed boxes constitute the base topology which covers the minimum loading case for each signal.

Allowed vias are either shown as circles on the topology diagrams or are otherwise documented under each diagram in a separate note.

The topology for a given configuration can be determined by adding the traces and loads within the dashed boxes to the base topology. Add only the traces and loads within boxes that apply for the desired configuration.

The permitted segment length ranges for that topology are read from the table below each topology diagram.

**Topology for Clock: CLK[1:0]**

Special attention must be given to the routing of the SDRAM clock signal(s) to ensure adequate signal quality, rise/fall time, minimum skew between clock edges at each SDRAM component, and predictable skew to motherboard chipset clocks. For that reason, all utilized clocks are made to look electrically similar by loading them with exactly four SDRAM loads. Clock signals must have either four SDRAM loads, or they must be terminated into 10 ohms and 10 pF. Trace lengths to the RC termination of unloaded clocks must be kept to an absolute minimum. Clock traces must be 5 mils wide with 15 mil spacing to any other signal including the clocks themselves.

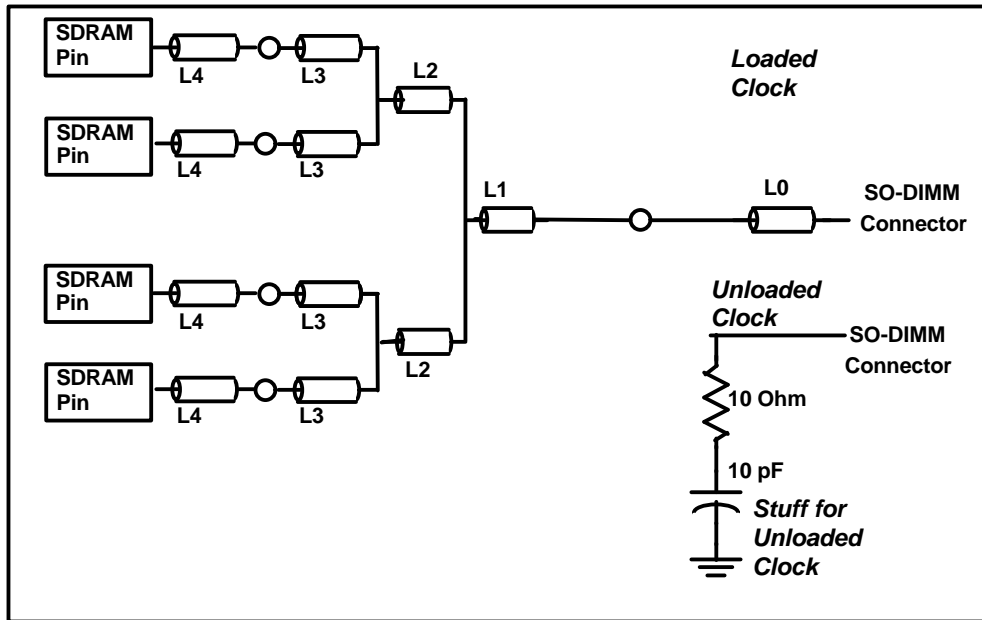

Note: Either the L2 or the L3 trace segment may contain one additional via which is not shown in the diagram.

**Figure 11: Signal routing topologies for Clocks**

**Table 10: Trace Length Table for Clock Topologies**

Segment	L0	L1	L2	L3	L4	Total Min	Total Max
Length	0.10	1.00	0.80	0.50	0.10	2.45	2.55
Tolerance	± 0.05	± 0.02	± 0.02	± 0.02	± 0.05		
Layer	Outer	Inner	Inner	Inner	Outer		

- 1 All distances are given in inches and should be kept within tolerance, and routed on the indicated layer.
- 2 Total Min and Total Max refer to the min and max respectively of L0 + L1 + L2 + L3 + L4. Also, the total min and max limits are tighter than the sum of the individual min and max lengths. This implies that not all individual segment lengths may be adjusted to the min or max value at the same time.

**Topology for Clock with an option to not stuff a row of SDRAM: CLK[1]**

If the PB is designed with the option to not stuff a row of SDRAM, a jumper must be included to disconnect the clock tree from the RC termination. The overall length of the net from the SO-DIMM pin to the SDRAM pin, through the jumper, must be the same as for clocks without this option. The diagram and table below explain this. In the picture, L0 is the sum of the trace lengths on both sides of the 0Ω jumper, and the distance through the 0Ω jumper. Trace lengths to the RC termination must be kept to an absolute minimum.

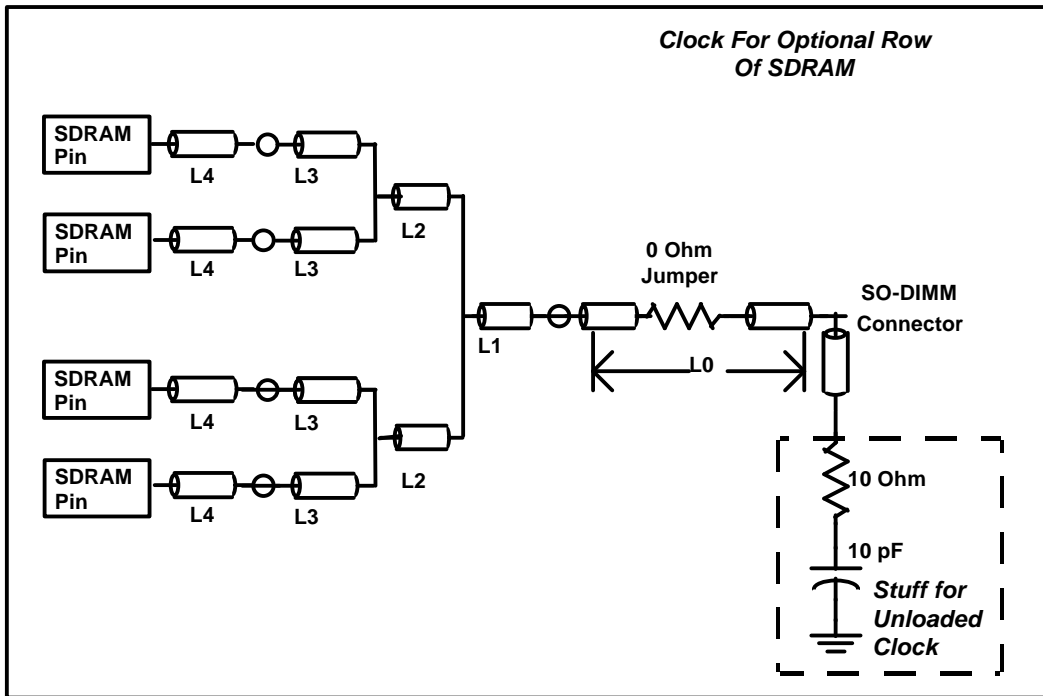

Note: Either the L2 or the L3 trace segment may contain one additional via which is not shown in the diagram.

**Figure 12: Signal routing topologies for Clocks to Rows with Optional Stuffing**

**Table 11: Trace Length Table for Clocks to Rows with Optional Stuffing**

Segment	L0	L1	L2	L3	L4	Total Min	Total Max
Length	0.25	0.85	0.80	0.50	0.10	2.45	2.55
Tolerance	± 0.05	± 0.02	± 0.02	± 0.02	± 0.05		
Layer	Outer	Inner	Inner	Inner	Outer		

- 1 All distances are given in inches and should be kept within tolerance, and routed on the indicated layer.
- 2 Total Min and Total Max refer to the min and max respectively of L0 + L1 + L2 + L3 + L4. Also, the total min and max limits are tighter than the sum of the individual min and max lengths. This implies that not all individual segment lengths may be adjusted to the min or max value at the same time.

**Topology for Data: DQ[63:0]**

These signals are routed using a balanced “T” topology on any layer. The table defines the line length ranges allowed for these signals.

**Figure 13: Signal routing topologies for Data**

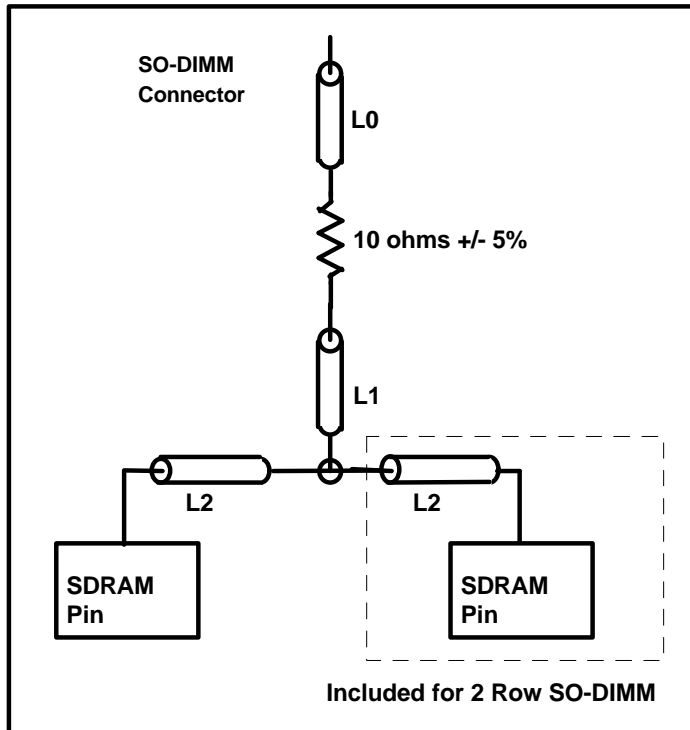

Note: The L1 trace segment may contain up to 2 additional vias which are not shown in the diagram.

**Table 12: Trace Length Table for Data Topologies**

Comp Width	# of loads	L0 Min	L0 Max	L1 Min	L1 Max	L2 Min	L2 Max	Total Min	Total Max
X16	1/2	0.10	0.50	0	0.90	0	0.25	0.60	1.00

- 1 All distances are given in inches
- 2 Total Min and Total Max refer to the min and max respectively of L0 + L1 + L2. Also, the total min and max limits are tighter than the sum of the individual min and max lengths. This implies that not all individual segment lengths may be adjusted to the min or max value at the same time.

**Topology for Data Mask: DQMB[7:0]**

These signals are routed using a balanced “T” topology on any layer. The tables define the line length ranges allowed for these signals.

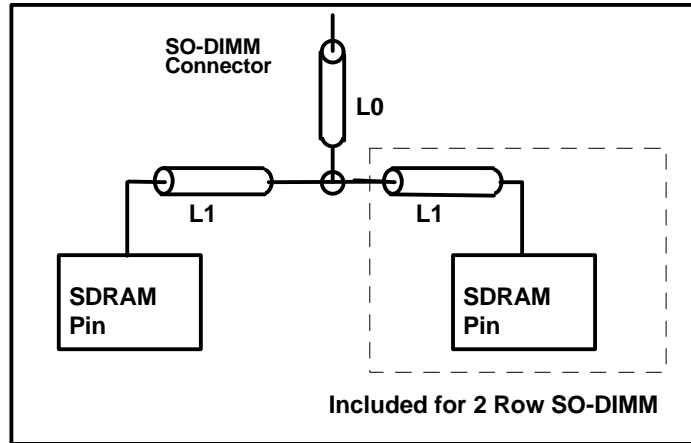

Note: The L0 trace segment may contain 1 additional via which is not shown in the diagram.

**Figure 14: Signal routing topologies for Data Mask (1/2 Loads)**

**Table 13: Trace Length Table for Data Mask Topologies (1/2 Loads)**

Comp Width	# loads	L0 Min	L0 Max	L1 Min	L1 Max	Total Min	Total Max
X16	1/2	0.75	1.10	0.00	0.30	1.00	1.40

<sup>1</sup> All distances are given in inches

**Topology for Chip Select: S#[1:0]**

This signal is routed using a balanced “comb” topology on any layer. The table below defines the line length ranges allowed for these signals.

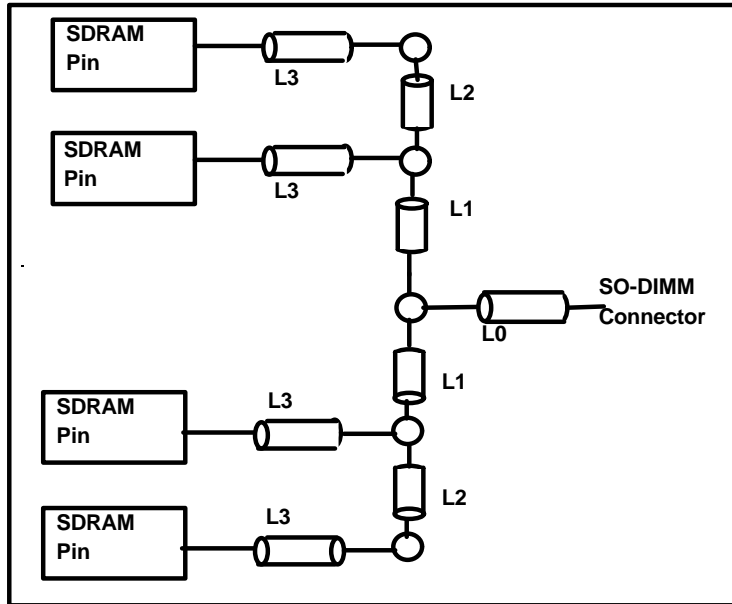

Note: The L0 trace may contain up to 2 vias which are not shown in the diagram.

**Figure 15: Signal routing topologies for Chip Select**

**Table 14: Trace Length Table for Chip Select Topologies**

Comp Width	# of loads	L0 Min	L0 Max	L1 Min	L1 Max	L2 Min	L2 Max	L3 Min	L3 Max	Total Min	Total Max
x16	4	0.50	1.10	0.10	0.50	0.0	0.60	0.05	0.35	1.00	2.30

- 1 All distances are given in inches.
- 2 Total distance is L0+L1+L3 or L0+L1+L2+L3. SO-DIMM connector to SDRAM Pin.

**Topology for Clock Enable: CKE#[1:0]**

This signal is routed using a balanced “comb” topology on any layer. The table below defines the line length ranges allowed for each trace segment.

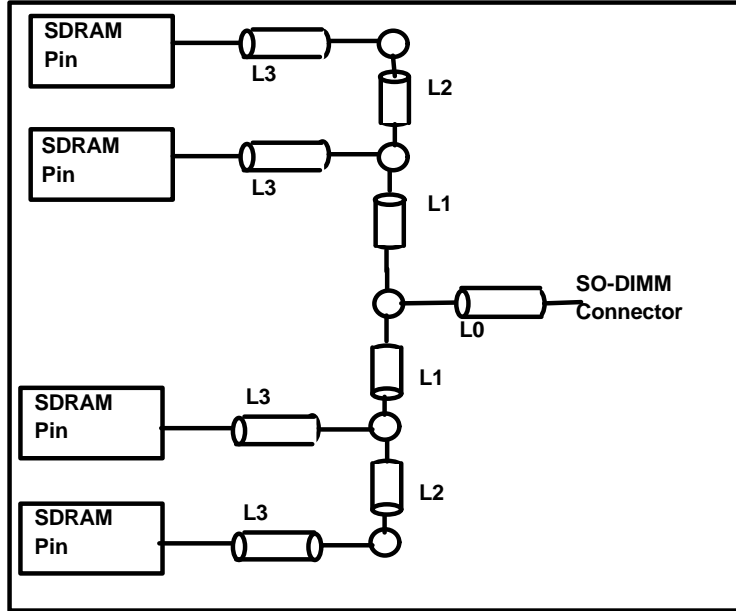

Note: The L0 trace may contain up to 2 vias which are not shown in the diagram.

**Figure 16: Signal routing topologies for Clock Enable**

**Table 15: Trace Length Tables for Clock Enable Topologies**

Comp Width	# of loads	L0 Min	L0 Max	L1 Min	L1 Max	L2 Min	L2 Max	L3 Min	L3 Max	Total Min	Total Max
x16	4	0.50	1.10	0.0	0.50	0.0	1.00	0.05	0.35	1.0	2.3

- 1 All distances are given in inches.
- 2 Total distance is L0+L1+L3 or L0+L1+L2+L3. SO-DIMM connector to SDRAM Pin.

**Double Cycle Signals: MAX, BAX, SRAS#, SCAS#, WE#**

These signals are routed using a balanced, double-sided “comb” topology on any layer. The table below defines the line length ranges allowed for these signals.

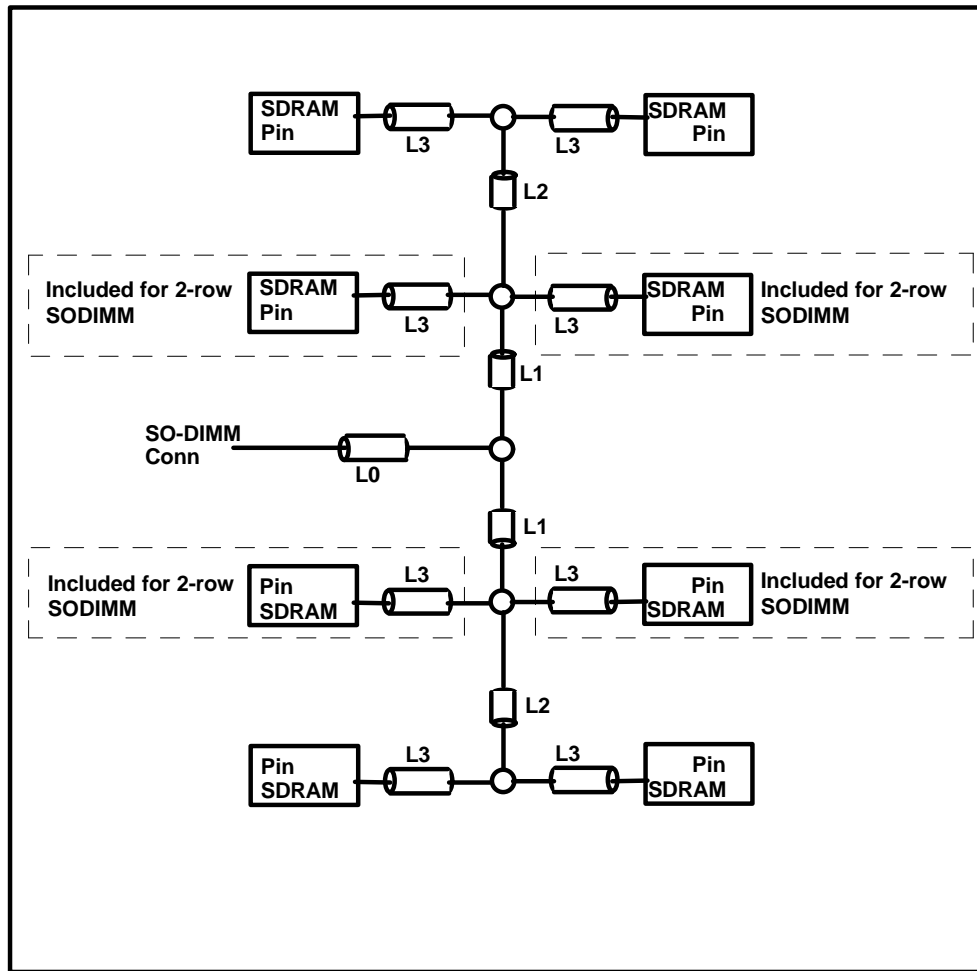

Note: The L0 trace may contain up to 2 vias which are not shown in the diagram.

**Figure 17: Signal routing topologies for Double Cycle Signals**

**Table 16: Trace Length Table for Double Cycle Signal Topologies**

Comp Width	# of loads	L0 Min	L0 Max	L1 Min	L1 Max	L2 Min	L2 Max	L3 Min	L3 Max	Total Min	Total Max
x16	4/8	0.50	2.50	0.0	1.10	0.0	1.00	0.10	0.40	0.75	4.0

1 All distances are given in inches

2 Total distance is L0+L1+L3 or L0+L1+L2+L3. SO-DIMM connector to SDRAM Pin.

## 7.0 SO-DIMM PCB and Final Assembly Labeling Requirements

### Printed Circuit Board Labeling

The printed circuit board is required to have the following labeling contained in etch or silk-screen:

Vendor name and part number

Flammability indicator (see Section 2 of this document, under Safety)

The text: SO-DIMM-REV#.#

(#.# corresponds to the revision of this SO-DIMM spec to which the PCB is designed)

### Assembled SO-DIMM Naming Convention

In order to be able to visually identify the critical parameters of a given SO-DIMM, the following naming convention will be used.

On component or sticker on DIMM (supplier option):

- use minimum 8point font

**PCX-abc-def**

Where X=MHz

a = CL value

b = trcd value

c = trp value

d = tac value

e = spd rev #

f = reserved

Example: PC100-322-620

is 100MHz, CL3, trcd=2, trp=2, tac=6, 2= spd rev 1.2 with the last digit reserved.

Note: A two digit designator for both the tac and spd fields is optional if appropriate.

Example: PC100-322-06120

is also 100MHz, CL3, trcd=2, trp=2, tac=6, 12= spd rev 1.2 with the last digit reserved.

## 8.0 SDRAM Component Specifications

The SDRAM components used with this 66/100 MHz SO-DIMM design spec MUST adhere to the most recent revision of the Intel "PC SDRAM Specification." Please refer to that document for all technical specifications and requirements of the SDRAM devices. Any violation of the requirements of the Intel PC SDRAM Component Specification constitutes a violation of the 66/100 MHz PC SDRAM Unbuffered SO-DIMM Specification.

## 9.0 EEPROM Component Specifications

The Serial Presence Detect function MUST be implemented on the PC SDRAM SO-DIMM. The component used and the data contents must adhere to the most recent version of the Intel "SDRAM Serial Presence Detect Specification". At the time of this writing, the current revision is 1.2A. Please refer to that document for all technical specifications and requirements of the serial presence detect devices. Any violation of the requirements of the Intel SDRAM Serial Presence Detect specification constitutes a violation of the PC SDRAM Unbuffered SO-DIMM Specification.